

PBFE – Push Button Frame Extender

The Push Button Frame Extender (PBFE) is intended to mount a Polara Push Button Frame (PBF) 6" or 12" away from the traffic pole, in order to position the Push Button closer to the start of the crosswalk. Push Button wires are routed inside of the tube to protect them against vandalism. Extender can be bolted or banded to the traffic pole.

Body Material: Galvanized Steel

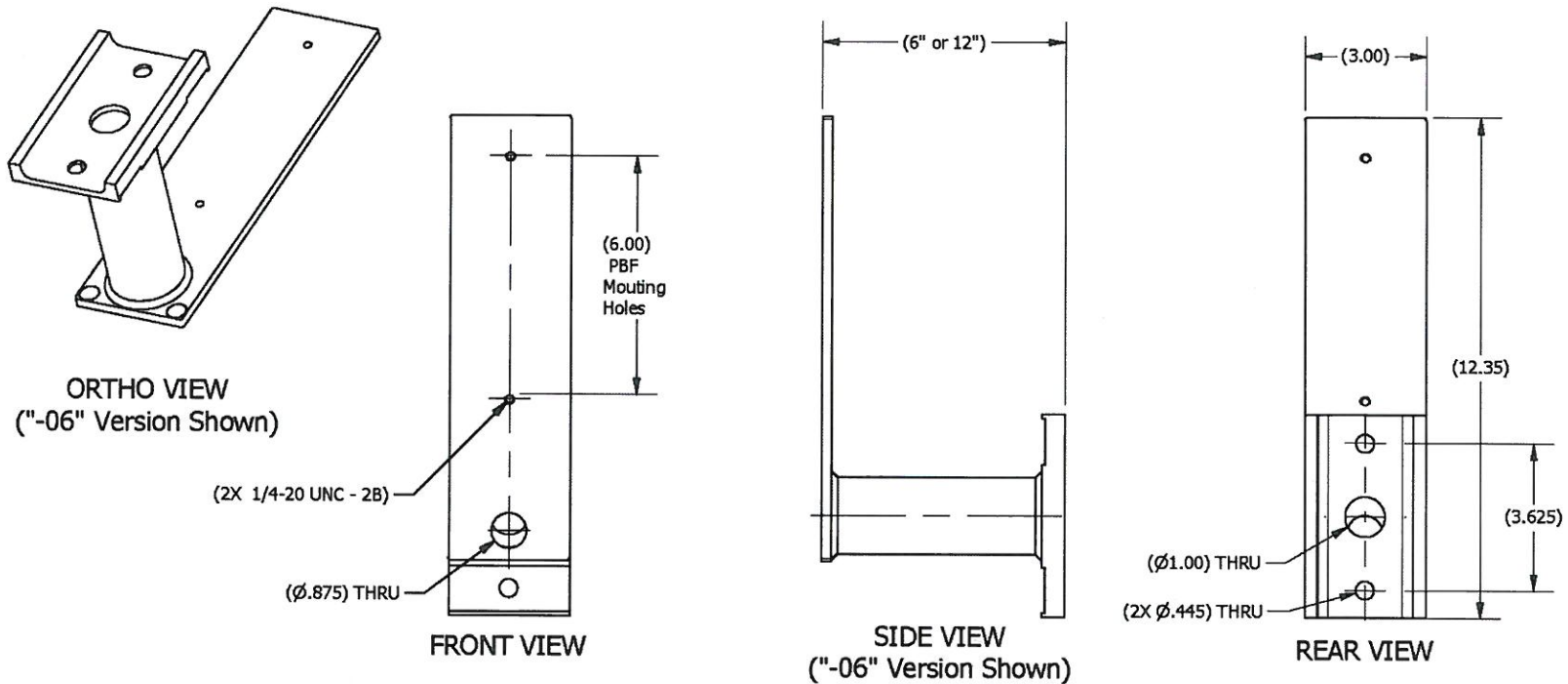

Product Ordering Information

PBFE-06	6" Extension
PBFE-12	12" Extension

Notes:

- 1) Applicable sections only of referenced standards.
- 2) All specifications subject to change without notice.

Dimensions are in inches.